

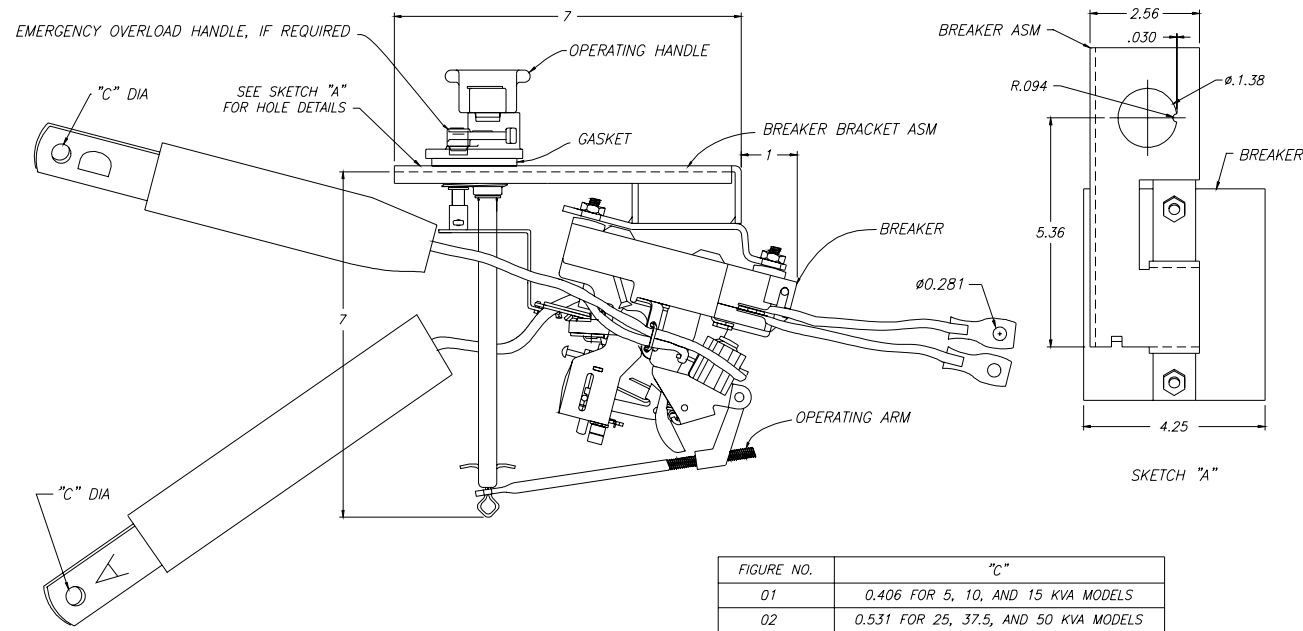

Single Phase Breaker on Bracket

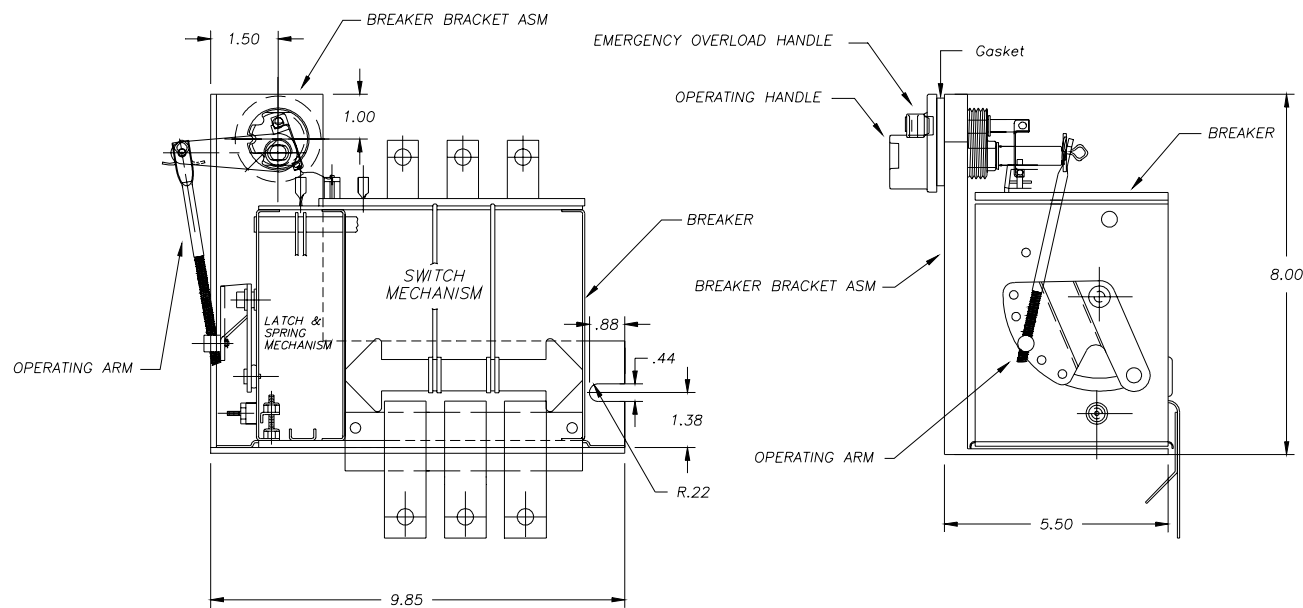

Three Phase Breaker on Bracket



H-J International, Inc.

H-J International, Inc. 3010 High Ridge Blvd High Ridge, Missouri, USA 63049
Tel: (636) 677-3421 Fax: (636) 376-1915
Web: www.h-jinternational.com

Rev: 1 Dated: 06/01/2002

H-J International, Inc.
File: NEW ERMCO Breaker Brochure II

ERMCO Components, Inc.

Low Voltage Circuit Breakers

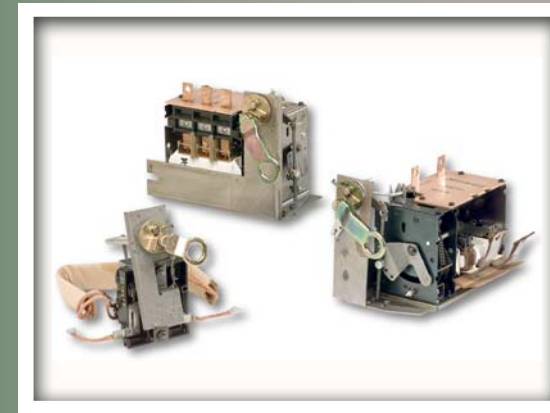

H-J International, Inc.

3010 High Ridge Blvd High Ridge, Missouri USA 63049
Tel: (636) 677-3421 Fax: (636) 376-1915
www.h-jinternational.com



...Breaker on Bracket

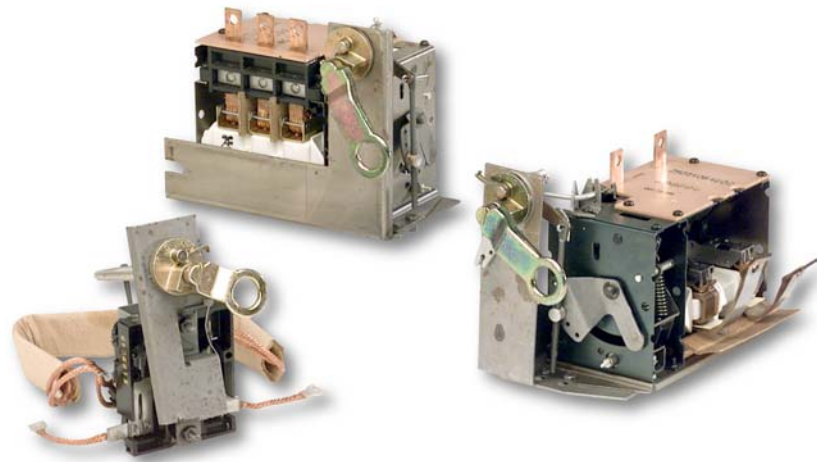

Description . . .

ECI internal oil-immersed secondary circuit breakers are designed for use as part of a protection package for either single or three phase distribution transformers. The breaker is electrically located between the transformer's low voltage coil and the low voltage bushings to provide protection against overloads and secondary faults.

The normal load cycle of a distribution transformer is characterized by a relatively light load during the greater part of the day, with one or more peaks lasting from a few minutes to a few hours. This permits operation of the transformer at loads exceeding its continuous self-cooled rating during short-time peaks, since the heat-storage capacity of the transformer results in a relatively slow increase of internal temperatures. Since the deteriorating effects of temperature are cumulative, it is possible to obtain satisfactory life from transformer insulation with peak temperatures exceeding those permitted for continuous loading if the duration of these temperatures is sufficiently restricted.

Transformers subjected to overloading or applied on lines without overload protection should be self-protected. Self-protected distribution transformers offer a complete, unified system of over-

H-J International, Inc.

load protection. The primary means of protecting the transformer is the circuit breaker, which is designed to give adequate protection from short circuits and severe overloads. Other protective equipment available from ECI includes internally mounted primary expulsion fuses.

FEATURES

Preadjusted

No linkage adjustments are required by the transformer manufacturer.

Ordered as a complete kit

One catalog number supplies the breaker, bracket, linkage and operating handle.

Rigid mounting bracket

Eliminates misalignment.

Special contact materials

To reduce arcing and eliminate the possibility of contacts welding in service.

High interrupting capability

To successfully clear bolted secondary faults without contact welding.

Rigidly interlocking contacts

To give simultaneous interruption of both breaker circuit contacts.

"BOB"

The breaker on bracket is a completely assembled breaker operating kit designed to provide the transformer manufacturer with simpler design and assembly as well as providing the utility customer a solution to the most common complaint associated with secondary breakers.

The breaker on bracket consists of a breaker mounted to a rigid steel bracket together with the operating handle and linkage. The package comes completely assembled and adjusted from the factory. One catalog number covers everything; no other components are required. When a signal light is used with any given breaker, it will need to be ordered separately. In addition, the light will require a separate hole in the transformer tank wall. Refer to the drawings for detailed information.

Installation in the transformer is simple and quick. The breaker and

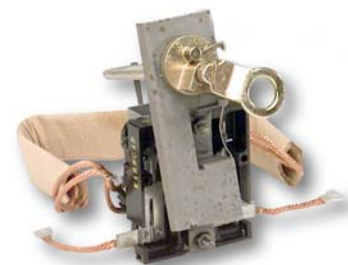

Type AHT-1
Thermal trip single-phase, 10-25 kVA

bracket is secured to the tank interior by means of the operating handle that passes through the tank wall. The

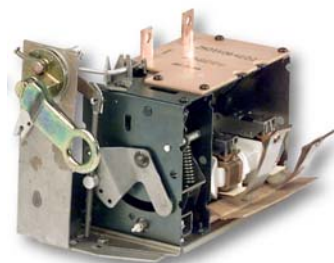

Type T-13
Thermal & magnetic trip, single-phase, 75-100 kVA

bracket is designed to rigidly mount the breaker in a fixed position relative to the operating handle. This assembly eliminates the engineering effort to layout the transformer interior

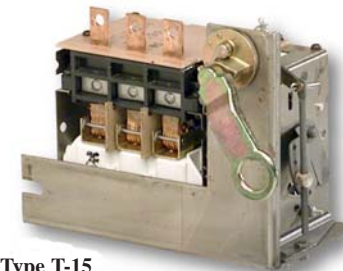

Type T-15
Thermal & magnetic trip, three-phase, 15 - 150 kVA

to insure the breaker is properly positioned. It also eliminates the time spent adjusting the breaker linkage on the transformer assembly line because these adjustments are set at the breaker factory.

An improperly adjusted link may result in an inoperable breaker when the utility customer receives the transformer. This problem can be accentuated if the breaker is mounted on a surface such as the flat tank wall of a pad-mounted transformer that can flex and change the distance between the breaker and operating handle. The breaker on bracket provides a solution to these assembly issues because the linkage connecting the breaker with the operating arm is factory adjusted by trained breaker technicians and locked in place before the breaker assembly is shipped to the transformer manufacturer.

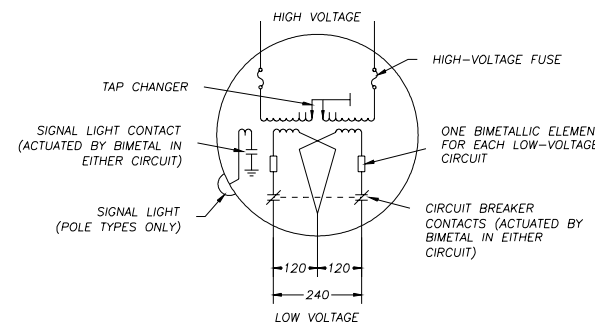

Circuit Breaker Wiring Diagram

Operation . . .

ECI internal oil-immersed, secondary circuit breakers are available for distribution transformers rated 10-167kVA with secondary voltages of 120/240 or 240/480 single-phase. Some transformers rated 25 kVA and all rated 37.5 kVA and above, single-phase, feature magnetic trip circuit breakers. Three-phase circuit breakers are available from 15-150 kVA at 480 volts and below, and from 45-300 kVA at 480 volts.

The circuit breaker is typically mounted inside the transformer tank, directly above the coil-and-core assembly. Operating linkage for the circuit breaker is brought out through the tank above the oil level through a double "O" ring seal or packing ring seal and connected to an external operating handle. On pad-mounted transformers, the circuit breaker operating handle is typically mounted in the low-voltage compartment. The circuit breaker operating handle is equipped with a metal loop for operation with standard hook stick.

The secondary circuit breaker is tripped by the deflection of bimetallic elements in series with the low-voltage leads heated by the combination of current in the bimetals and the temperature of the oil. As maximum safe operating load is approached, the bimetals deflect and trip the operating mechanism. That opens the contacts and disconnects the secondary load from the transformer, protecting the transformer from burn-out. Positive mechanical interlock between the circuit-breaker poles assures simultaneous opening of all poles. If the operator tries to close the breaker while a fault exists on the line, the breaker will open even though the circuit-breaker operating handle is held in the closed position.

Magnetic trip circuit breakers offer improved performance in fuse coordination, fault-interrupting capability and with the ECI T-12 circuit breaker, lower short-circuit forces in transformer windings. The magnetic trip circuit breaker follows the normal thermal time current characteristics except when the secondary current exceeds 10-

15 times rated load current. Under those circumstances, the magnetic trip takes over and bypasses the bimetal, causing immediate circuit-breaker trip by the activation of the magnetic trip plate.

Operating Handle . . .



Circuit Breaker Operating Handle With Emergency Overload Lever

The above shows the circuit breaker operating handle and emergency overload lever. To open the low-voltage circuit manually, move the handle so the pointer moves from "C"(closed) to "O"(open). When the pointer coincides with the "O" position, the low-voltage circuit is open. To close the breaker, move the handle to position "C"(closed). If the breaker has tripped thermally or magnetically, move the handle to position "R"(reset) to engage the latch mechanism, then to "C"(closed). The "L"(light) position is not used on a pad-mounted transformer. If desired, the breaker-operating handle can be operated with a switch hook.

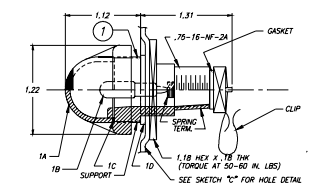

Circuit Breaker Signal Light Drawing Emergency Overload

Through the use of the emergency overload lever, self-protected transformers are able to carry overloads in excess of those normally permitted by the circuit breakers. The lever, mounted on the circuit-breaker operating handle, can be moved to permit changing from normal to emergency overload setting. If a transformer circuit breaker has tripped and the bimetals are still at trip temperature, the use of the emergency overload lever may allow the operator to close the circuit breaker to restore service.